

# RETAINER FOR SURFACE MOUNTING OF ANTI-PANIC AND ACCESS EMERGENCY DOORS

## AE/V-RPE300

### Description

Emergency, panic and access door retainer for surface mounting.  
Keeps the door closed at rest.



### Dimensions

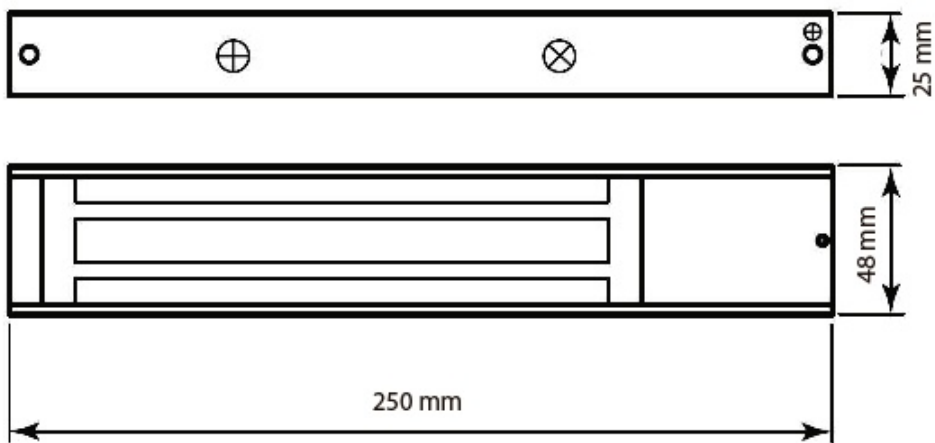

### TECHNICAL CHARACTERISTICS

Operating temperature:	-10°C + 55°C
Protection degree:	IP40
Power:	24Vdc
Consumption:	250mA
Clamping force:	300Kg / 2490N